

Operating Instructions

Dolphin Diagnostic Basic Pool Cleaner
(Model: LA)

Instructions d'opération

Dolphin Diagnostic Basic le nettoyeur de piscines
(Model: LA)

Instruzioni per l'uso

Dolphin Diagnostic Basic el limpiador de piscinas
(Model: LA)

Instrucciones de manejo

Dolphin Diagnostic Basic il pulitore per piscine
(Model: LA)

Bedienungsanleitung

Dolphin Diagnostic Basic der Pool-Reiniger
(Model: LA)

Werkwijze instructies

Dolphin Diagnostic Basic de zwembedreiniger
(Model: LA)

Instruções de Operação

Dolphin Diagnostic Basic limpador de piscinas
(Model: LA)

Руководство по эксплуатации

Dolphin Diagnostic Basic очиститель бассейнов
(Модель LA)



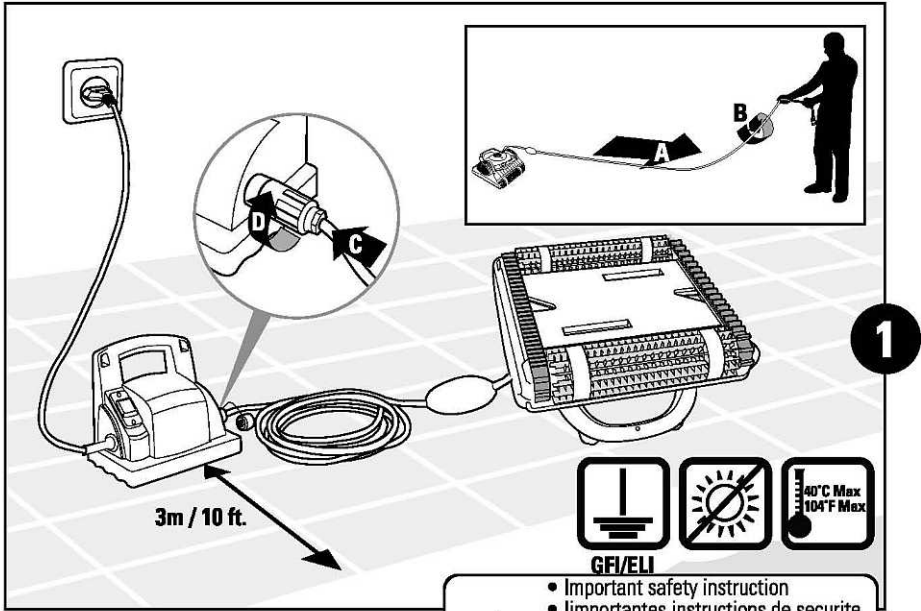

- Keep power supply out of standing water
- Gardez l'alimentation électrique hors de l'eau
- Tenere l'alimentatore distante dall'acqua stagnante
- Aleje la fuente de alimentación del agua estancada
- Halten sie die stromversorgung von stehendem wasser fern
- Plaats de stroomtoevoer nooit in het water
- Manter a fonte de alimentação longe de água estagnada
- Избегать попадания воды в область системы электропитания

- Use only original Diagnostic Basic power supply - factory wired for 100/115/230 vac mains supply
- N'utilisez que l'alimentation originale Diagnostic Basic - cablee en usine pour un courant de secteur 100/115/230 vac
- Usare solo l'alimentatore elettrico originale Diagnostic Basic - predisposto in fabbrica per alimentazione rete a 100/115/230 vac
- Utilice solamente fuente de alimentación de diagnóstico basic - cableado en fábrica para alimentar redes de 100/115/230 vac
- Benutzen sie nur die Diagnostic Basic-stromversorgung - fabrikfertig für 100/115/230 vac-netzanschluss
- Gebruik alleen de originele diagnostic basic elektriciteitsaanvoer - de fabriekskabel is geschikt voor 100/115/230 vac elektriciteit
- Utilize somente Fonte de Alimentação original de Diagnostic Basic - Ligação feita em fábrica para rede de energia elétrica de 100/115/230 VCA
- Использовать только оригинальную систему электропитания - заводская проводка рассчитана на сеть 100/115/230 В переменного тока



- GFI/ELI**
- Important safety instruction
 - Importantes instrucciones de seguridad
 - Importanti istruzioni di sicurezza
 - Importante instrucciones de seguridad
 - Wichtige sicherheitsvorschrift
 - Belangrijke veiligheidsinstructie
 - Instrução de segurança importante
 - Важные инструкции по технике безопасности

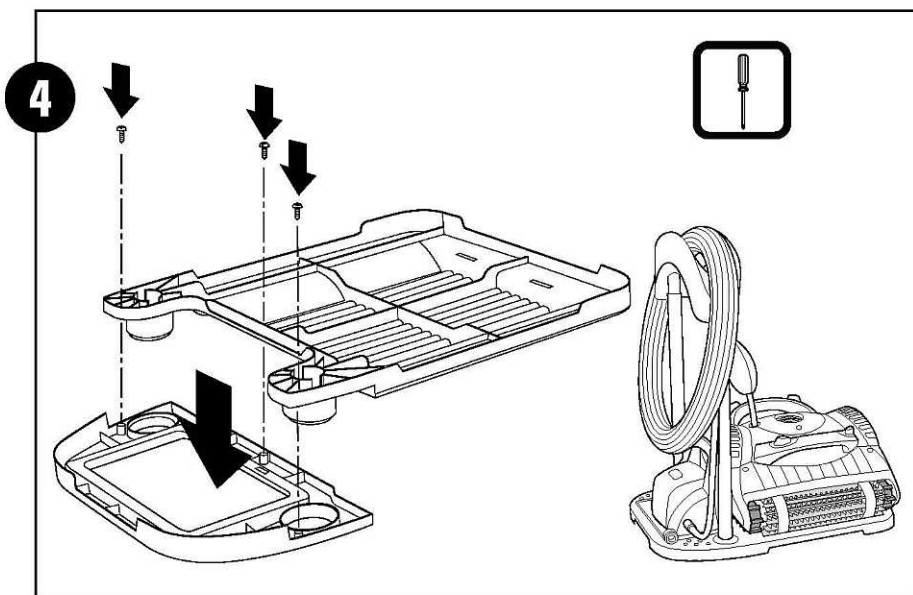
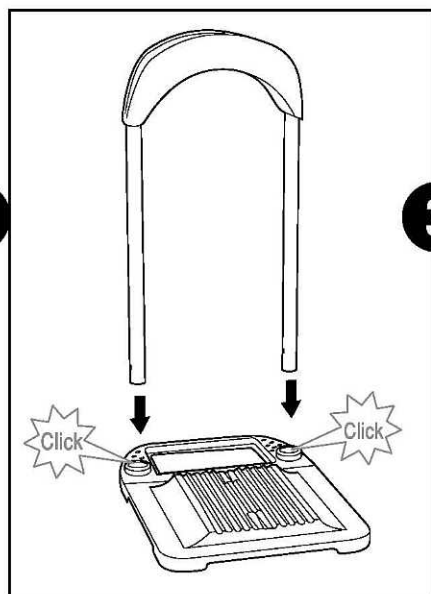
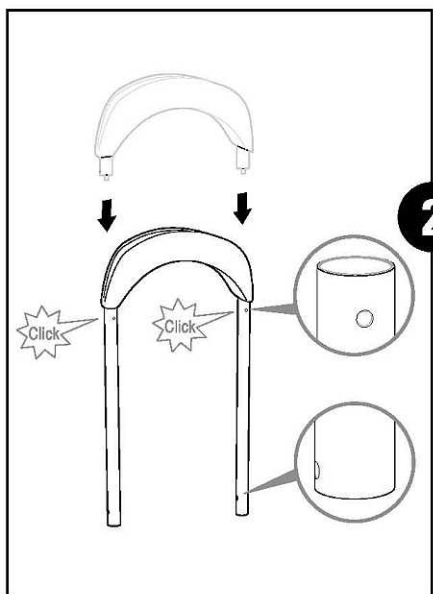



- If pva rings / wonder rings are dry, soak them in water until soft
- Si les brosses pva / wonder sont secs, trempez-les dans l'eau jusqu'à ce qu'ils redeviennent doux.
- Se gli anelli pva / gli anelli mobili sono asciutti, ammolliarli in acqua finché diventano soffici
- Si los anillos pva / anillos wonder están secos, remójelos en agua hasta que se ablanden.
- Aenn die pva-ringe/wunderlinge trocken sind, tränken sie sie mit wasser, bis sie weich werden.
- Als de pva ringen/wonder ringen droog zijn, week u ze in water totdat ze zacht zijn geworden
- Se os anéis de pva/anéis wonder secarem, molhe-os em água até ficarem maleáveis
- В СЛУЧАЕ, ЕСЛИ КОЛЬЦА ПВА ИЛИ ПОДВИЖНЫЕ КОЛЬЦА СУХИЕ, СЛЕДУЕТ ПОДДЕРЖАТЬ ИХ В ВОДЕ ДО ТЕХ ПОР, ПОКА ОНИ НЕ СТАНУТ МЯГКИМИ.

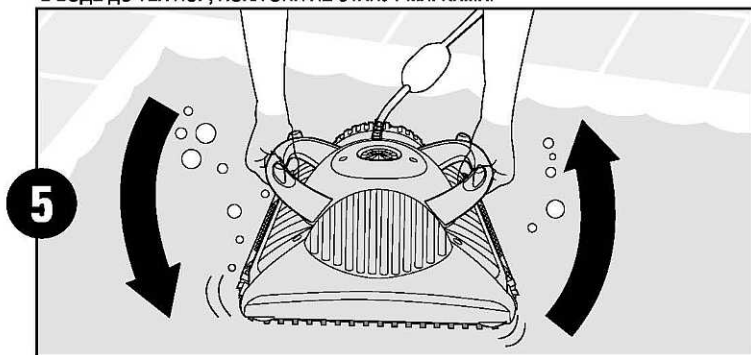

CHLORINE
2 - 4 ppm

PH
7 - 7.4

T
32°C 90°F
12°C 54°F

NaCl
max
4000 ppm

- Shake robot from side to side or turn it upside down to release trapped air
- Secouez le robot sur les côtés ou de haut en bas pour libérer les bulles d'air
- Scuotere il robot di da un lato all'altro o girarlo a testa in giù per liberarne l'aria imprigionata
- Sacuda el robot de lado a lado o póngalo boca abajo para soltar el aire retenido
- Schwenken sie den roboter von seite zu seite oder kippen sie ihn um, um den lufteneinschluss zu befreien
- Schud de robot heen en weer, of houd hem onderste boven om vastgelopen lucht vrij te laten
- Sacudir o robô lateralmente ou virar de cima para baixo para liberar ar confinado
- Потрясти робот из стороны в сторону или перевернуть его для удаления скопившегося внутри воздуха

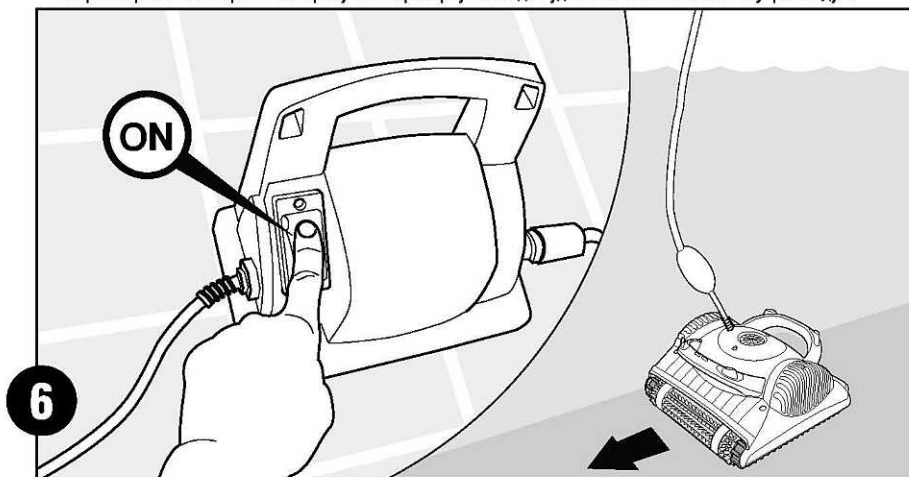

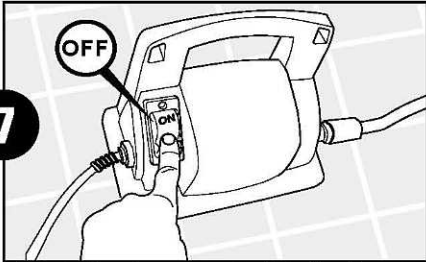

7

- Robot will perform automatic shut-off at the end of the cleaning cycle
- Le robot s'eteindra automatiquement a la fin du cycle de nettoyage
- Il robot si disattiverà automaticamente alla fine del ciclo di pulizia
- El robot efectuará el apagado automático al término del ciclo de limpieza.
- Der roboter wird am ende des waschzyklus automatisch abschalten
- De robot slaat automatisch af aan het einde van de schoonmaak cyclus
- O robô desligará automaticamente no fim do ciclo de limpeza
- Робот автоматически отключает систему по завершении цикла очистки.

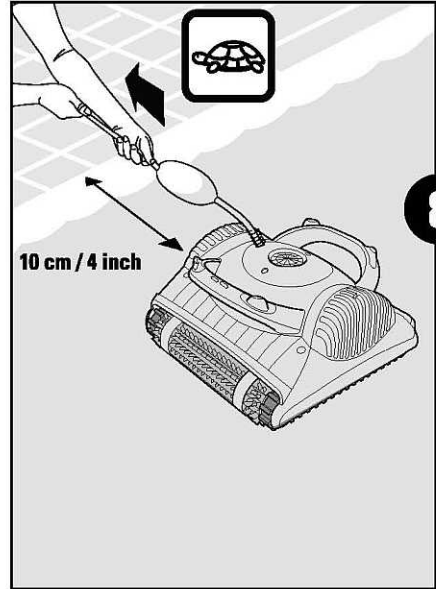

10 cm / 4 inch

8

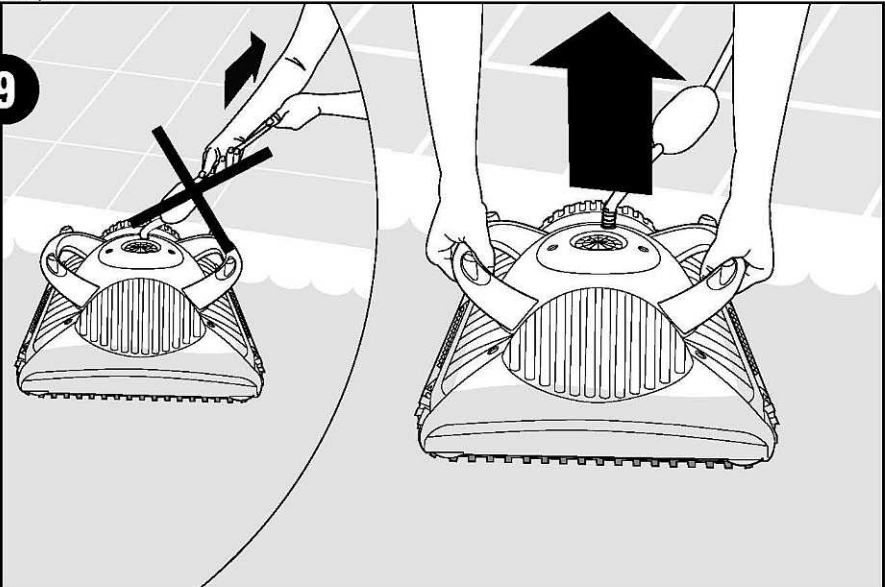

9



10

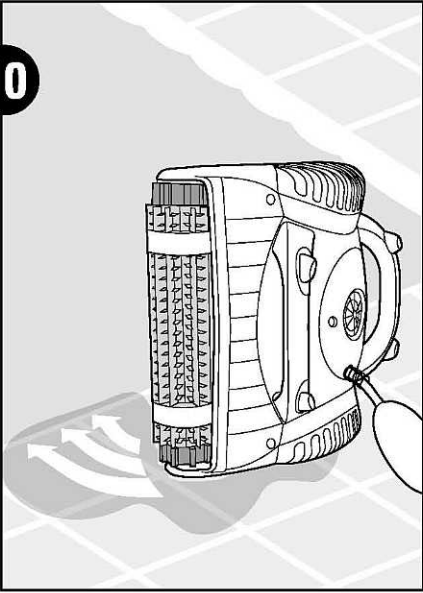

11

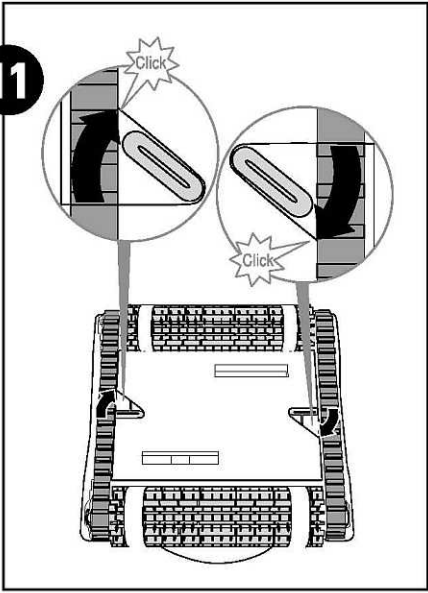

12

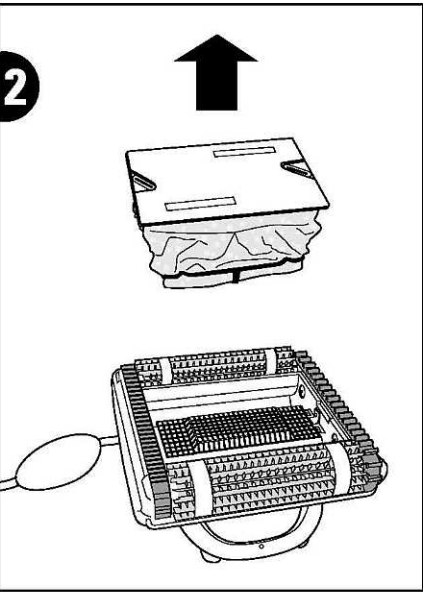

13

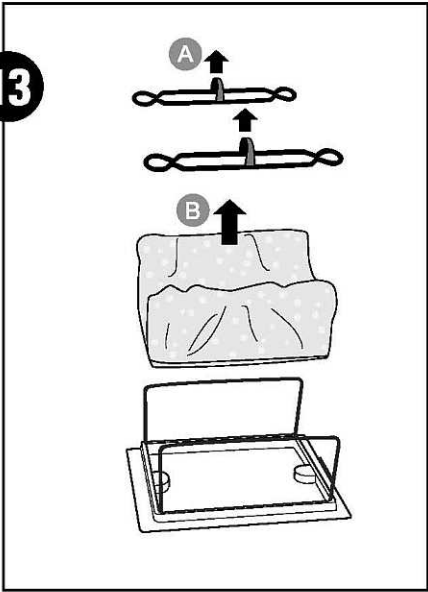

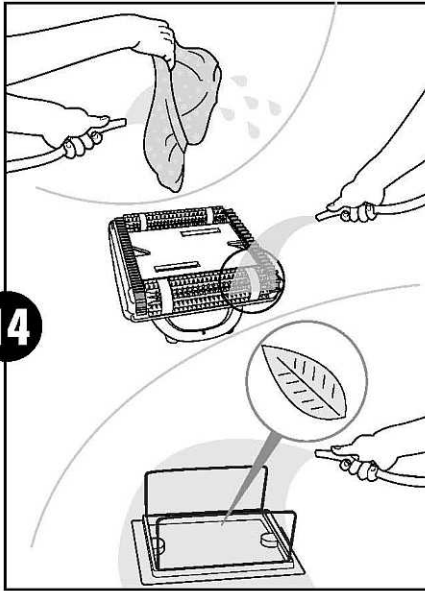

- It is recommended to periodically wash filter bag in a washing machine. Use synthetic cleaning program
- Il est recommandé de laver périodiquement le filtre dans la machine à laver. Utilisez le programme de nettoyage synthétique
- È raccomandabile lavare periodicamente il sacchetto-filtro in una macchina lavatrice. Selezionare un programma di lavaggio per materiali sintetici
- Se recomienda lavar periódicamente la bolsa del filtro en una máquina lavadora. Utilice el programa para el lavado de fibras sintéticas
- Es ist empfehlenswert, den filterbeutel regelmäßig in einer waschmaschine zu waschen. Betätigen sie ein synthetisches waschprogramm
- Aanbevolen wordt om de filterzak regelmatig in de wasmachine met een syntetisch wasprogramma te wassen
- Recomenda-se lavar periodicamente o saco de filtragem em uma máquina de lavar. Utilize o programa de limpeza sintética
- Рекомендуется периодически промывать мешок фильтра в стиральной машине. Использовать программу для стирки синтетических материалов.

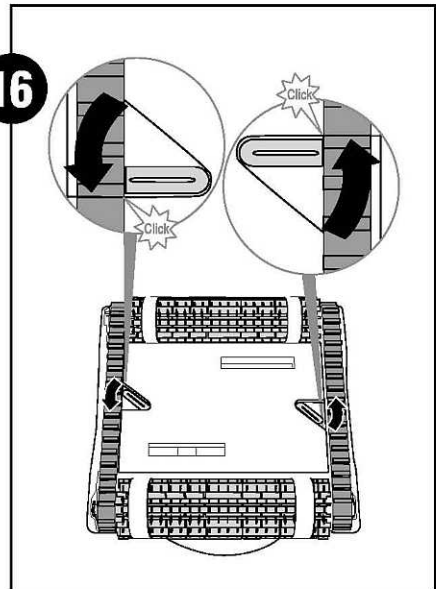
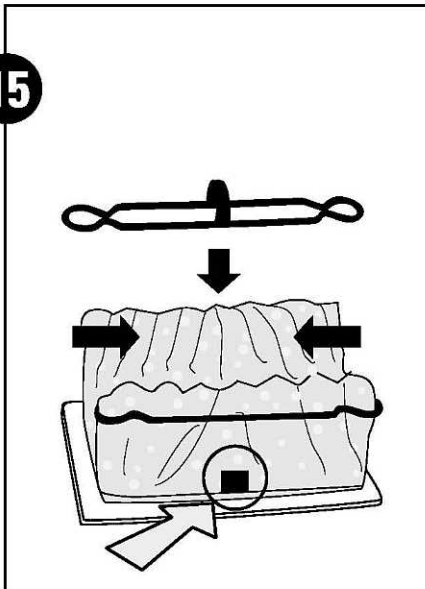

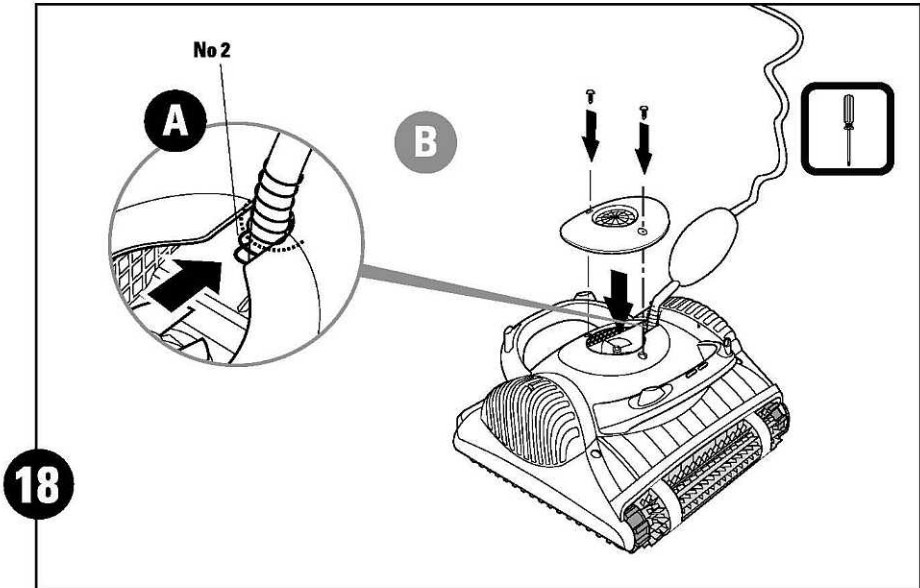
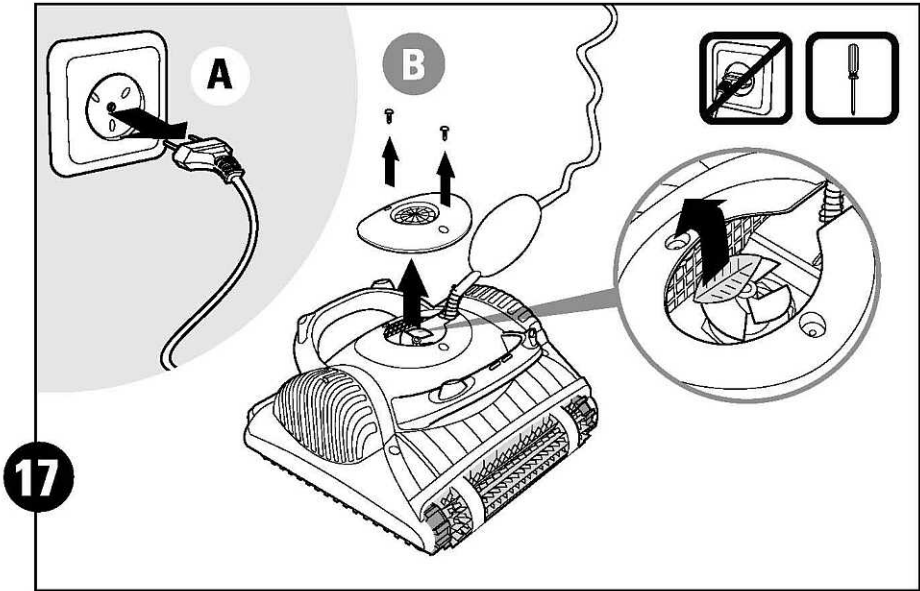



19

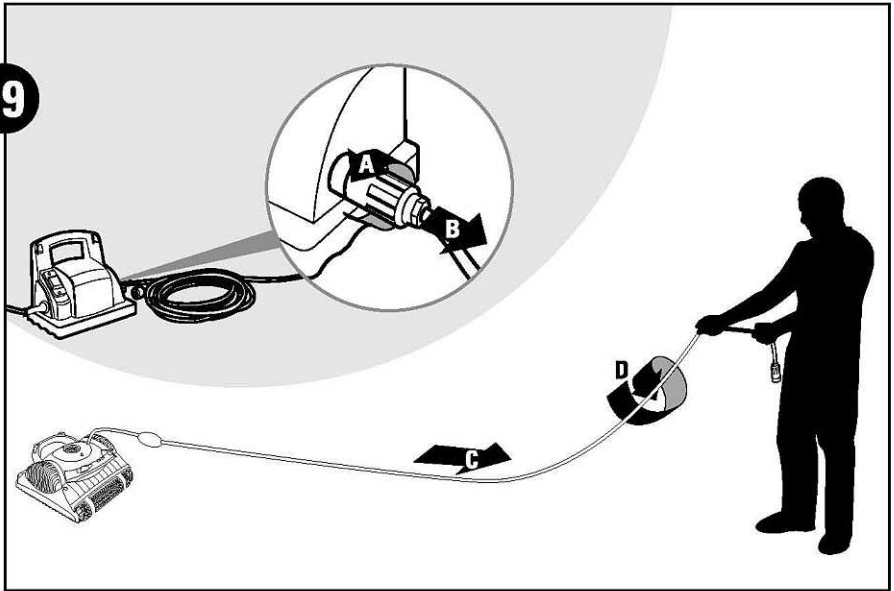

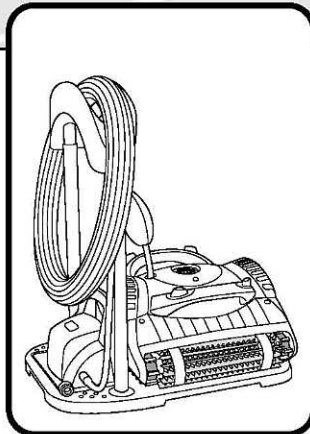
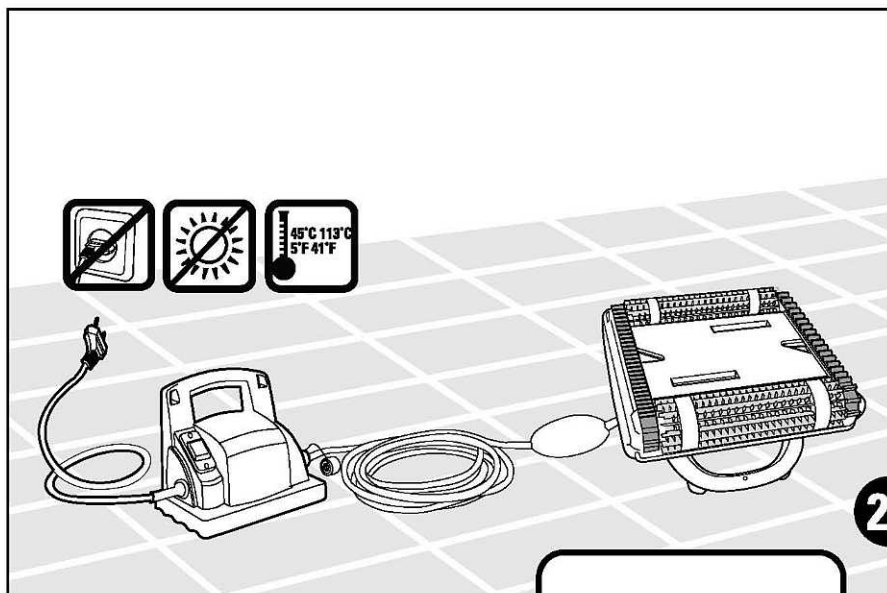

- The components below (21) are available at your authorized dealer
- Les composants ci-dessous (21) sont disponibles chez votre revendeur agréé
- I componenti che seguono (21) sono disponibili presso il distributore autorizzato
- Los componentes listados más abajo (21) se pueden obtener de nuestro distribuidor autorizado
- Die Komponenten unten (21) sind bei ihrem befugten Händler erhältlich
- Onderstaande onderdelen (21) zijn beschikbaar bij uw geautoriseerde dealer
- Os componentes abaixo (21) estão disponíveis nos postos autorizados
- ДЕТАЛИ, ПЕРЕЧИСЛЕННЫЕ НИЖЕ (21), МОЖНО ПРИОБРЕСТИ У ВАШЕГО УПОЛНОМОЧЕННОГО ДИЛЕРА

